

Chapter 10. Dwelling Units and Sleeping Units

1001 General

1001.1 Scoping. Dwelling units and sleeping units required to be Accessible units, Type A units, Type B units, or units with accessible communication features by the scoping provisions adopted by the administrative authority shall comply with the applicable provisions of Chapter 10.

1002 Accessible Units

1002.1 General. Accessible units shall comply with Section 1002.

1002.2 Primary Entrance. The accessible primary entrance shall be on an accessible route from public and common areas. The primary entrance shall not be to a bedroom.

1002.3 Accessible Route. Accessible routes within Accessible units shall comply with Section 1002.3. Exterior spaces less than 30 inches (760 mm) in depth or width shall comply with Sections 1002.3.1, 1002.3.3, 302, and 303.

1002.3.1 Location. At least one accessible route shall connect all spaces and elements that are a part of the unit. Where only one accessible route is provided, it shall not pass through bathrooms and toilet rooms, closets, or similar spaces.

EXCEPTION: An accessible route is not required to unfinished attics and unfinished basements that are part of the unit.

1002.3.2 Turning Space. All rooms served by an accessible route shall provide a turning space complying with Section 304.

1002.3.3 Components. Accessible routes shall consist of one or more of the following elements: walking surfaces with a slope not steeper than 1:20, ramps, elevators, and platform lifts.

1002.4 Walking Surfaces. Walking surfaces that are part of an accessible route shall comply with Section 403.

1002.5 Doors and Doorways. The primary entrance door to the unit, and all other doorways intended for user passage, shall comply with Section 404.

EXCEPTION: Existing doors to hospital patient sleeping rooms shall be exempt from the requirement for space at the latch side provided the door is 44 inches (1120 mm) minimum in width.

1002.6 Ramps. Ramps shall comply with Section 405.

1002.7 Elevators. Elevators within the unit shall comply with Section 407, 408, or 409.

1002.8 Platform Lifts. Platform lifts within the unit shall comply with Section 410.

1002.9 Operable Parts. Lighting controls, electrical switches and receptacle outlets, environmental controls, appliance controls, operating hardware for operable windows, plumbing fixture controls, and user controls for security or intercom systems shall comply with Section 309.

EXCEPTIONS:

1. Receptacle outlets serving a dedicated use.
2. One receptacle outlet shall not be required to comply with Section 309 where all of the following conditions are met:
 - (a) the receptacle outlet is above a length of countertop that is uninterrupted by a sink or appliance;
 - (b) at least one receptacle outlet complying with Section 1002.9 is provided for that length of countertop; and
 - (c) all other receptacle outlets provided for that length of countertop comply with Section 1002.9.
3. Floor receptacle outlets.
4. HVAC diffusers.
5. Controls mounted on ceiling fans.
6. Where redundant controls other than light switches are provided for a single element, one control in each space shall not be required to be accessible.

1002.10 Laundry Equipment. Washing machines and clothes dryers shall comply with Section 611.

1002.11 Toilet and Bathing Facilities. Toilet and bathing facilities shall comply with Sections 603 through 610.

1002.11.1 Vanity Counter Top Space.

If vanity counter top space is provided in nonaccessible dwelling or sleeping units within the same facility, equivalent vanity counter top

space, in terms of size and proximity to the lavatory, shall also be provided in Accessible units.

1002.12 Kitchens. Kitchens shall comply with Section 804. At least one work surface, 30 inches (760 mm) minimum in length, shall comply with Section 902.

1002.13 Windows. Where operable windows are provided, at least one window in each sleeping, living, or dining space shall have operable parts complying with Section 1002.9. Each required operable window shall have operable parts complying with Section 1002.9.

1002.14 Storage Facilities. Where storage facilities are provided, they shall comply with Section 905. Kitchen cabinets shall comply with Section 804.5.

1003 Type A Units

1003.1 General. Type A units shall comply with Section 1003.

1003.2 Primary Entrance. The accessible primary entrance shall be on an accessible route from public and common areas. The primary entrance shall not be to a bedroom.

1003.3 Accessible Route. Accessible routes within Type A units shall comply with Section 1003.3. Exterior spaces less than 30 inches (760 mm) in depth or width shall comply with Sections 1003.3.1, 1003.3.3, 302, and 303.

1003.3.1 Location. At least one accessible route shall connect all spaces and elements that are a part of the unit. Where only one accessible route is provided, it shall not pass through bathrooms and toilet rooms, closets, or similar spaces.

EXCEPTION: An accessible route is not required to unfinished attics and unfinished basements that are part of the unit.

1003.3.2 Turning Space. All rooms served by an accessible route shall provide a turning space complying with Section 304.

EXCEPTION: Toilet rooms and bathrooms that are not required to comply with Sections 1003.11.5 through 1003.11.9.

1003.3.3 Components. Accessible routes shall consist of one or more of the following elements: walking surfaces with a slope not steeper than 1:20, ramps, elevators, and platform lifts.

1003.4 Walking Surfaces. Walking surfaces that are part of an accessible route shall comply with Section 403.

1003.5 Doors and Doorways. The primary entrance door to the unit, and all other doorways

intended for user passage, shall comply with Section 404.

EXCEPTIONS:

1. Thresholds at exterior sliding doors shall be permitted to be $\frac{3}{4}$ inch (19 mm) maximum in height, provided they are beveled with a slope not greater than 1:2.
2. In toilet rooms and bathrooms not required to comply with Section 1003.11, maneuvering clearances required by Section 404.2.3 are not required on the toilet room or bathroom side of the door.

1003.6 Ramps. Ramps shall comply with Section 405.

1003.7 Elevators. Elevators within the unit shall comply with Section 407, 408, or 409.

1003.8 Platform Lifts. Platform lifts within the unit shall comply with Section 410.

1003.9 Operable Parts. Lighting controls, electrical switches and receptacle outlets, environmental controls, appliance controls, operating hardware for operable windows, plumbing fixture controls, and user controls for security or intercom systems shall comply with Section 309.

EXCEPTIONS:

1. Receptacle outlets serving a dedicated use.
2. One receptacle outlet is not required to comply with Section 309 where all of the following conditions are met:
 - (a) the receptacle outlet is above a length of countertop that is uninterrupted by a sink or appliance; and
 - (b) at least one receptacle outlet complying with Section 1003.9 is provided for that length of countertop; and
 - (c) all other receptacle outlets provided for that length of countertop comply with Section 1003.9.
3. Floor receptacle outlets.
4. HVAC diffusers.
5. Controls mounted on ceiling fans.
6. Where redundant controls other than light switches are provided for a single element, one control in each space shall not be required to be accessible.

1003.10 Laundry Equipment. Washing machines and clothes dryers shall comply with Section 611.

1003.11 Toilet and Bathing Facilities.

1003.11.1 General. All toilet and bathing areas shall comply with Section 1003.11.4. At least one toilet and bathing facility shall comply with Section 1003.11. At least one lavatory, one water closet and either a bathtub or shower within the unit shall comply with Section 1003.11. The accessible toilet and bathing fixtures shall be in a single toilet/bathing area, such that travel between fixtures does not require travel through other parts of the unit.

1003.11.2 Doors. Doors shall not swing into the clear floor space or clearance for any fixture.

EXCEPTION: Where a clear floor space complying with Section 305.3 is provided within the room beyond the arc of the door swing.

1003.11.3 Overlap. Clear floor spaces, clearances at fixtures and turning spaces are permitted to overlap.

1003.11.4 Reinforcement. Reinforcement shall be provided for the future installation of grab bars and shower seats at water closets, bathtubs, and shower compartments. Where walls are located to permit the installation of grab bars and seats complying with Sections 604.5, 607.4, 608.3 and 608.4, reinforcement shall be provided for the future installation of grab bars and seats meeting those requirements.

EXCEPTION: Reinforcement is not required in a room containing only a lavatory and a water closet, provided the room does not contain the only lavatory or water closet on the accessible level of the dwelling unit.

1003.11.5 Lavatory. Lavatories shall comply with Section 606.

EXCEPTION: Cabinetry shall be permitted under the lavatory, provided:

- (a) the cabinetry can be removed without removal or replacement of the lavatory;
- (b) the floor finish extends under such cabinetry; and
- (c) the walls behind and surrounding cabinetry are finished.

1003.11.6 Mirrors. Mirrors above lavatories shall have the bottom edge of the reflecting surface 40 inches (1015 mm) maximum above the floor.

1003.11.7 Water Closet. Water closets shall comply with Section 1003.11.7.

1003.11.7.1 Location. The water closet shall be positioned with a wall to the rear and to one

side. The centerline of the water closet shall be 16 inches (405 mm) minimum and 18 inches (455 mm) maximum from the sidewall.

1003.11.7.2 Clearance. A clearance around the water closet of 60 inches (1525 mm) minimum, measured perpendicular from the side wall, and 56 inches (1420 mm) minimum, measured perpendicular from the rear wall, shall be provided.

1003.11.7.3 Overlap. The required clearance around the water closet shall be permitted to overlap the water closet, associated grab bars, paper dispensers, coat hooks, shelves, accessible routes, clear floor space required at other fixtures, and the wheelchair turning space. No other fixtures or obstructions shall be located within the required water closet clearance.

EXCEPTION: A lavatory complying with Section 1003.11.5 shall be permitted on the rear wall 18 inches (455 mm) minimum from the centerline of the water closet where the clearance at the water closet is 66 inches (1675 mm) minimum measured perpendicular from the rear wall.

1003.11.7.4 Height. The top of the water closet seat shall be 15 inches (380 mm) minimum and 19 inches (485 mm) maximum above the floor, measured to the top of the seat.

1003.11.7.5 Flush Controls. Hand operated flush controls shall comply with Section 1003.9. Flush controls shall be located on the open side of the water closet.

1003.11.8 Bathtub. Bathtubs shall comply with Section 607.

EXCEPTIONS:

1. The removable in-tub seat required by Section 607.3 is not required.
2. Counter tops and cabinetry shall be permitted at the control end of the clearance, provided such counter tops and cabinetry can be removed and the floor finish extends under such cabinetry.

1003.11.9 Shower. Showers shall comply with Section 608.

EXCEPTION: Counter tops and cabinetry shall be permitted at the control end of the clearance, provided such counter tops and

cabinetry can be removed and the floor finish extends under such cabinetry.

1003.12 Kitchens. Kitchens shall comply with Section 1003.12.

1003.12.1 Clearance. Clearance complying with Section 1003.12.1 shall be provided.

1003.12.1.1 Minimum Clearance. Clearance between all opposing base cabinets, counter tops, appliances, or walls within kitchen work areas shall be 40 inches (1015 mm) minimum.

1003.12.1.2 U-Shaped Kitchens. In kitchens with counters, appliances, or cabinets on three contiguous sides, clearance between all opposing base cabinets, countertops, appliances, or walls within kitchen work areas shall be 60 inches (1525 mm) minimum.

1003.12.2 Clear Floor Space. Clear floor spaces required by Sections 1003.12.3 through 1003.12.6 shall comply with Section 305.

1003.12.3 Work Surface. At least one section of counter shall provide a work surface 30 inches (760 mm) minimum in length complying with Section 1003.12.3.

1003.12.3.1 Clear Floor Space. A clear floor space, positioned for a forward approach to the work surface, shall be provided. Knee and toe clearance complying with Section 306 shall be provided. The clear floor space shall be centered on the work surface.

EXCEPTION: Cabinetry shall be permitted under the work surface, provided:

- (a) the cabinetry can be removed without removal or replacement of the work surface,

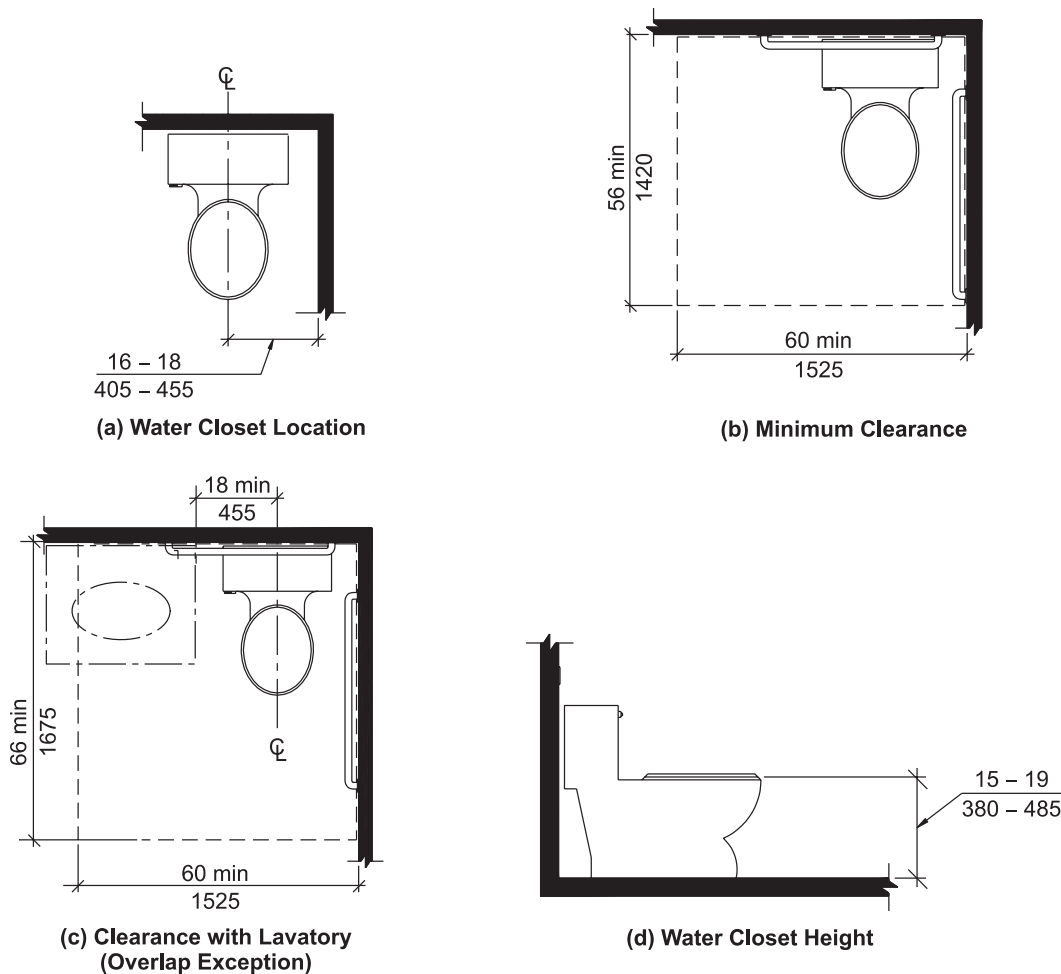

Fig. 1003.11.7
Water Closets in Type A Units

- (b) the floor finish extends under such cabinetry, and
- (c) the walls behind and surrounding cabinetry are finished.

1003.12.3.2 Height. The work surface shall be 34 inches (865 mm) maximum above the floor.

EXCEPTION: A counter that is adjustable to provide a work surface at variable heights 29 inches (735 mm) minimum and 36 inches (915 mm) maximum above the floor, or that can be relocated within that range without cutting the counter or damaging adjacent cabinets, walls, doors, and structural elements, shall be permitted.

1003.12.3.3 Exposed Surfaces. There shall be no sharp or abrasive surfaces under the exposed portions of work surface counters.

1003.12.4 Sink. Sinks shall comply with Section 1003.12.4.

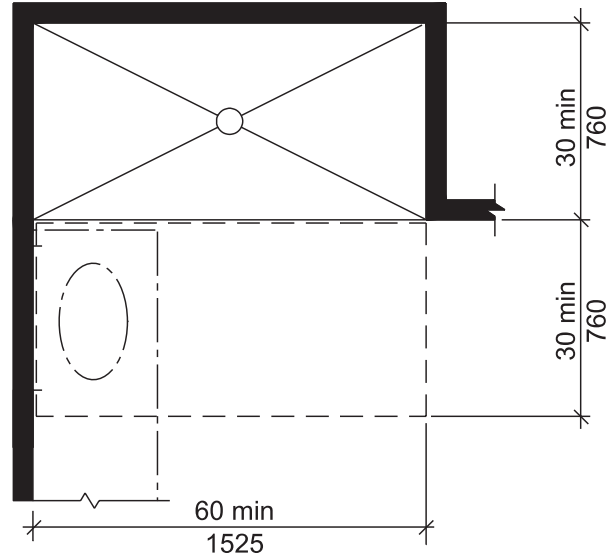

Note: Sink permitted per Section 608.2.2

Fig. 1003.11.9
Standard Roll-in-Type Shower
Compartment in Type A Units

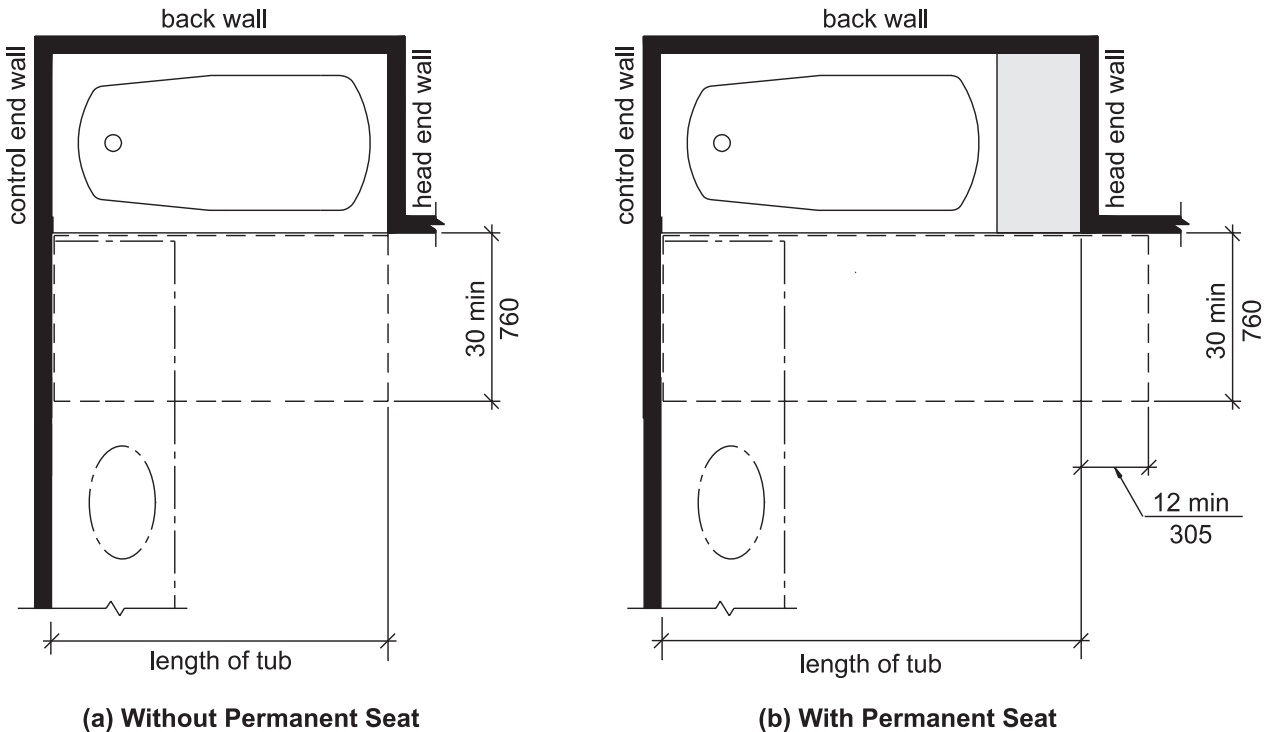

Fig. 1003.11.8
Clearance for Bathtubs in Type A Units

1003.12.4.1 Clear Floor Space. A clear floor space, positioned for a forward approach to the sink, shall be provided. Knee and toe clearance complying with Section 306 shall be provided. The clear floor space shall be centered on the sink bowl.

EXCEPTIONS:

1. The requirement for knee and toe clearance shall not apply to more than one bowl of a multi-bowl sink.
2. Cabinetry shall be permitted to be added under the sink, provided:
 - (a) the cabinetry can be removed without removal or replacement of the sink,
 - (b) the floor finish extends under such cabinetry, and
 - (c) the walls behind and surrounding cabinetry are finished.

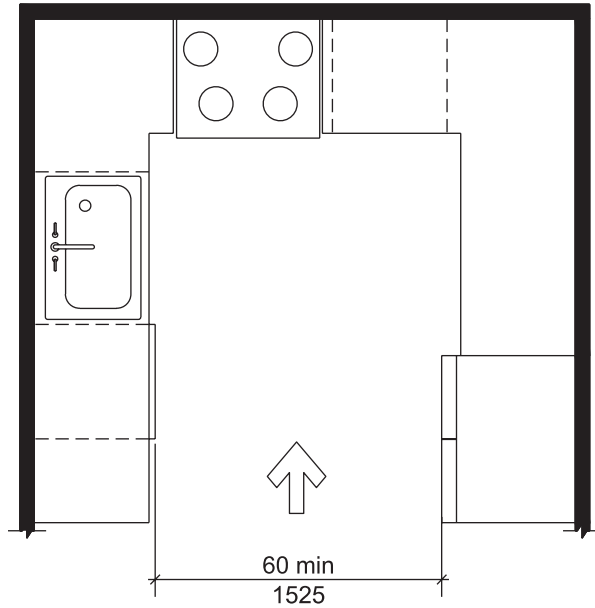

Fig. 1003.12.1.2
U-Shaped Kitchen Clearance in Type A Units

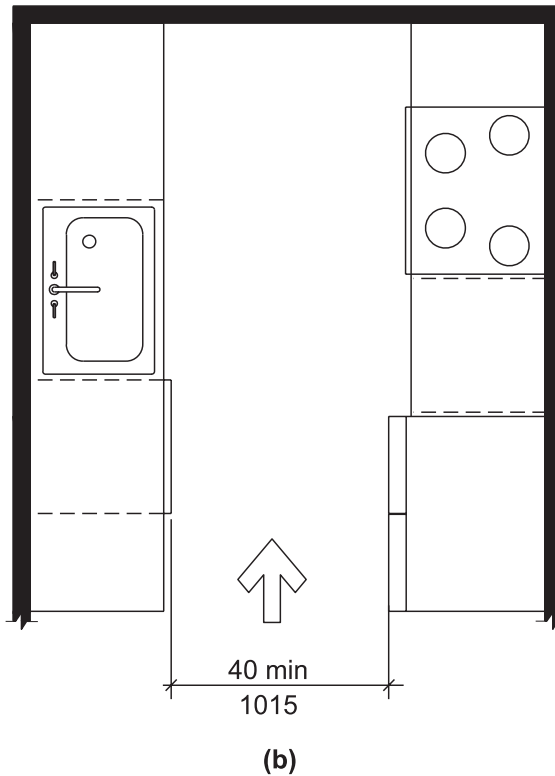
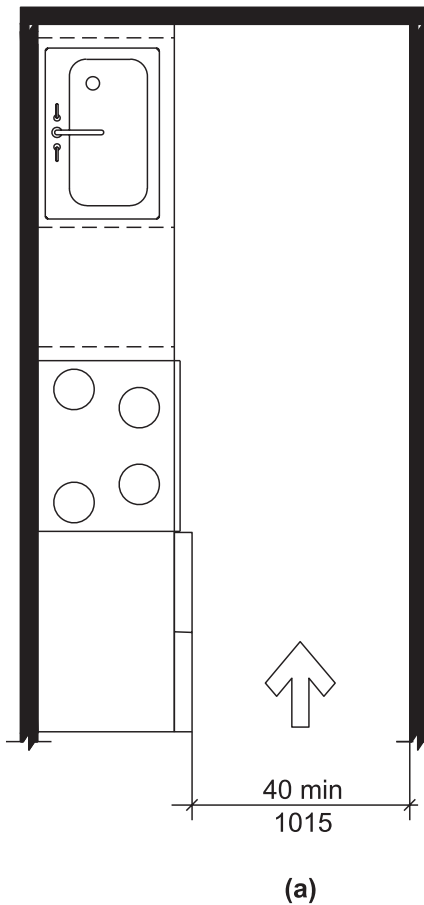

Fig. 1003.12.1.1
Minimum Kitchen Clearance in Type A Units

1003.12.4.2 Height. The front of the sink shall be 34 inches (865 mm) maximum above the floor, measured to the higher of the rim or counter surface.

EXCEPTION: A sink and counter that is adjustable to variable heights 29 inches (735 mm) minimum and 36 inches (915 mm) maximum above the floor, or that can be relocated within that range without cutting the counter or damaging adjacent cabinets, walls, doors and structural elements, provided rough-in plumbing permits connections of supply and drain pipes for sinks mounted at the height of 29 inches (735 mm), shall be permitted.

1003.12.4.3 Faucets. Faucets shall comply with Section 309.

1003.12.4.4 Exposed Pipes and Surfaces. Water supply and drain pipes under sinks shall be insulated or otherwise configured to protect against contact. There shall be no sharp or abrasive surfaces under sinks.

1003.12.5 Kitchen Storage. A clear floor space, positioned for a parallel or forward approach to the kitchen cabinets, shall be provided.

1003.12.6 Appliances. Where provided, kitchen appliances shall comply with Section 1003.12.6.

1003.12.6.1 Operable Parts. All appliance controls shall comply with Section 1003.9.

EXCEPTIONS:

1. Appliance doors and door latching devices shall not be required to comply with Section 309.4.

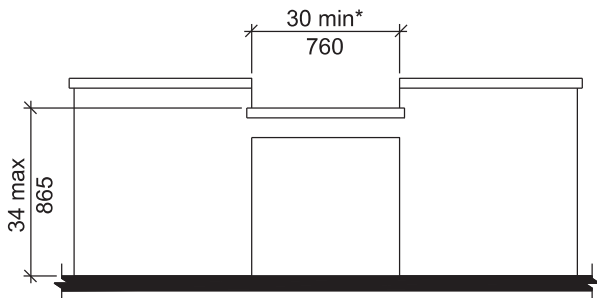

* 36 min. (915) if part of T-shaped turning space per Sections 304.3.2 and 1003.3.2

Fig. 1003.12.3
Work Surface in Kitchen for Type A Units

2. Bottom-hinged appliance doors, when in the open position, shall not be required to comply with Section 309.3.

1003.12.6.2 Clear Floor Space. A clear floor space, positioned for a parallel or forward approach, shall be provided at each kitchen appliance. Clear floor spaces shall be permitted to overlap.

1003.12.6.3 Dishwasher. A clear floor space, positioned adjacent to the dishwasher door, shall be provided. The dishwasher door in the open position shall not obstruct the clear floor space for the dishwasher or an adjacent sink.

1003.12.6.4 Range or Cooktop. A clear floor space, positioned for a parallel or forward approach to the space for a range or cooktop, shall be provided. Where the clear floor space is positioned for a forward approach, knee and toe clearance complying with Section 306 shall be provided. Where knee and toe space is provided, the underside of the range or cooktop shall be insulated or otherwise configured to protect from burns, abrasions, or electrical shock. The location of controls shall not require reaching across burners.

1003.12.6.5 Oven. Ovens shall comply with Section 1003.12.6.5. Ovens shall have controls on front panels, on either side of the door.

1003.12.6.5.1 Side-Hinged Door Ovens.

Side-hinged door ovens shall have a countertop positioned adjacent to the latch side of the oven door.

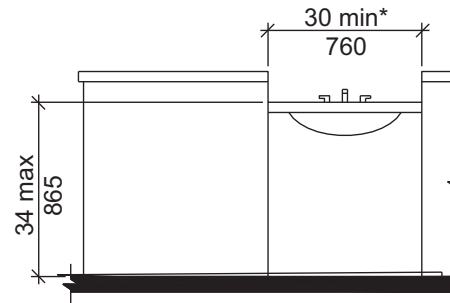

* 36 min. (915) if part of T-shaped turning space per Sections 304.3.2 and 1003.3.2

Fig. 1003.12.4
Kitchen Sink for Type A Units

1003.12.6.5.2 Bottom-Hinged Door Ovens. Bottom-hinged door ovens shall have a countertop positioned adjacent to one side of the door.

1003.12.6.6 Refrigerator/Freezer. Combination refrigerators and freezers shall have at least 50 percent of the freezer compartment shelves, including the bottom of the freezer 54 inches (1370 mm) maximum above the floor when the shelves are installed at the maximum heights possible in the compartment. A clear floor space, positioned for a parallel approach to the space dedicated to a refrigerator/freezer, shall be provided. The centerline of the clear floor space shall be offset 24 inches (610 mm) maximum from the centerline of the dedicated space.

1003.12.6.7 Trash Compactor. A clear floor space, positioned for a parallel or forward approach to the trash compactor, shall be provided.

1003.13 Windows. Where operable windows are provided, at least one window in each sleeping, living, or dining space shall have operable parts complying with Section 1003.9. Each required operable window shall have operable parts complying with Section 1003.9.

1003.14 Storage Facilities. Where storage facilities are provided, they shall comply with Section 1003.14. Kitchen cabinets shall comply with Section 1003.12.5.

1003.14.1 Clear Floor Space. A clear floor space complying with Section 305, positioned for a parallel or forward approach, shall be provided at each storage facility.

1003.14.2 Height. A portion of the storage area of each storage facility shall comply with at least one of the reach ranges specified in Section 308.

1003.14.3 Operable Parts. Operable parts on storage facilities shall comply with Section 309.

1004 Type B Units

1004.1 General. Type B units shall comply with Section 1004.

1004.2 Primary Entrance. The accessible primary entrance shall be on an accessible route from public and common areas. The primary entrance shall not be to a bedroom.

1004.3 Accessible Route. Accessible routes within Type B units shall comply with Section 1004.3.

1004.3.1 Location. At least one accessible route shall connect all spaces and elements that are a part of the unit. Where only one accessible route is provided, it shall not pass through bathrooms and toilet rooms, closets, or similar spaces.

EXCEPTION: One of the following is not required to be on an accessible route:

1. A raised floor area in a portion of a living, dining, or sleeping room; or
2. A sunken floor area in a portion of a living, dining, or sleeping room; or
3. A mezzanine that does not have plumbing fixtures or an enclosed habitable space.

1004.3.2 Components. Accessible routes shall consist of one or more of the following elements: walking surfaces with a slope not steeper than 1:20, doorways, ramps, elevators, and platform lifts.

1004.4 Walking Surfaces. Walking surfaces that are part of an accessible route shall comply with Section 1004.4.

1004.4.1 Width. Clear width of an accessible route shall comply with Section 403.5.

1004.4.2 Changes in Level. Changes in level shall comply with Section 303.

EXCEPTION: Where exterior deck, patio or balcony surface materials are impervious, the finished exterior impervious surface shall be 4 inches (100 mm) maximum below the floor level of the adjacent interior spaces of the unit.

1004.5 Doors and Doorways. Doors and doorways shall comply with Section 1004.5.

1004.5.1 Primary Entrance Door. The primary entrance door to the unit shall comply with Section 404.

EXCEPTION: Maneuvering clearances required by Section 404.2.3 shall not be required on the unit side of the primary entrance door.

1004.5.2 User Passage Doorways. Doorways intended for user passage shall comply with Section 1004.5.2.

1004.5.2.1 Clear Width. Doorways shall have a clear opening of $31\frac{3}{4}$ inches (810 mm) minimum. Clear opening of swinging doors shall be measured between the face of the door and stop, with the door open 90 degrees.

1004.5.2.2 Thresholds. Thresholds shall comply with Section 303.

EXCEPTION: Thresholds at exterior sliding doors shall be permitted to be $\frac{3}{4}$ inch (19 mm) maximum in height, provided they are beveled with a slope not steeper than 1:2.

1004.5.2.3 Automatic Doors. Automatic doors shall comply with Section 404.3.

1004.5.2.4 Double Leaf Doorways. Where an inactive leaf with operable parts higher than 48 inches (1220 mm) or lower than 15 inches (380 mm) above the floor is provided, the active leaf shall provide the clearance required by Section 1004.5.2.1.

1004.6 Ramps. Ramps shall comply with Section 405.

1004.7 Elevators. Elevators within the unit shall comply with Section 407, 408, or 409.

1004.8 Platform Lifts. Platform lifts within the unit shall comply with Section 410.

1004.9 Operable Parts. Lighting controls, electrical switches and receptacle outlets, environmental controls, and user controls for security or intercom systems shall comply with Sections 309.2 and 309.3.

EXCEPTIONS:

1. Receptacle outlets serving a dedicated use.
2. One receptacle outlet is not required to comply with Sections 309.2 and 309.3 where all of the following conditions are met:
 - (a) the receptacle outlet is above a length of countertop that is uninterrupted by a sink or appliance; and
 - (b) at least one receptacle outlet complying with Section 1004.9 is provided for that length of countertop; and
 - (c) all other receptacle outlets provided for that length of countertop comply with Section 1004.9.
3. Floor receptacle outlets.
4. HVAC diffusers.
5. Controls mounted on ceiling fans.
6. Controls or switches mounted on appliances.
7. Plumbing fixture controls.

1004.10 Laundry Equipment. Washing machines and clothes dryers shall comply with Section 1004.10.

1004.10.1 Clear Floor Space. A clear floor space complying with Section 305.3, positioned for parallel approach, shall be provided. The clear floor space shall be centered on the appliance.

1004.11 Toilet and Bathing Facilities. Toilet and bathing fixtures shall comply with Section 1004.11.

EXCEPTION: Fixtures on levels not required to be accessible.

1004.11.1 Clear Floor Space. Clear floor space required by Section 1004.11.3.1 or 1004.11.3.2 shall comply with Sections 1004.11.1 and 305.3.

1004.11.1.1 Doors. Doors shall not swing into the clear floor space for any fixture.

EXCEPTION: Where a clear floor space complying with Section 305.3, excluding knee and toe clearances under elements, is provided within the room beyond the arc of the door swing.

1004.11.1.2 Knee and Toe Clearance. Clear floor space at fixtures shall be permitted to include knee and toe clearances complying with Section 306.

1004.11.1.3 Overlap. Clear floor spaces shall be permitted to overlap.

1004.11.2 Reinforcement. Reinforcement shall be provided for the future installation of grab bars and shower seats at water closets, bathtubs, and shower compartments. Where walls are located to permit the installation of grab bars and seats complying with Sections 604.5, 607.4, 608.3 and 608.4, reinforcement shall be provided for the future installation of grab bars and seats meeting those requirements.

EXCEPTION: Reinforcement is not required in a room containing only a lavatory and a water closet, provided the room does not contain the only lavatory or water closet on the accessible level of the unit.

1004.11.3 Toilet and Bathing Rooms. Either all toilet and bathing rooms provided shall comply with Section 1004.11.3.1 (Option A), or one toilet and bathing room shall comply with Section 1004.11.3.2 (Option B).

1004.11.3.1 Option A. Each fixture provided shall comply with Section 1004.11.3.1.

EXCEPTION: A lavatory and a water closet in a room containing only a lavatory and

water closet, provided the room does not contain the only lavatory or water closet on the accessible level of the unit.

1004.11.3.1.1 Lavatory. A clear floor space complying with Section 305.3, positioned for a parallel approach, shall be provided. The clear floor space shall be centered on the lavatory.

EXCEPTIONS:

1. A lavatory complying with Section 606.
2. Cabinetry shall be permitted under the lavatory provided such cabinetry can be removed without removal or replacement of the lavatory, and the floor finish extends under such cabinetry.

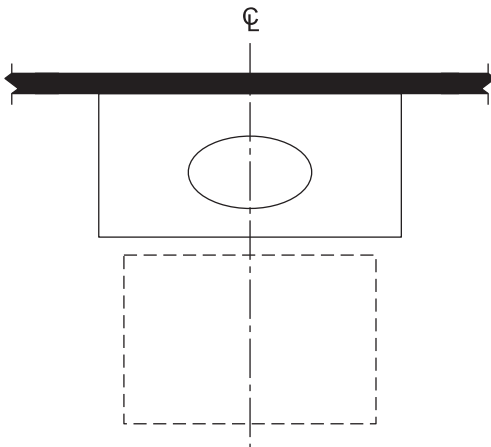

Clear Floor Space

**Fig. 1004.11.3.1.1
Lavatory in Type B Units—
Option A Bathrooms**

1004.11.3.1.2 Water Closet. The lateral distance from the centerline of the water closet to a bathtub or lavatory shall be 18 inches (455 mm) minimum on the side opposite the direction of approach and 15 inches (380 mm) minimum on the other side. The lateral distance from the centerline of the water closet to an adjacent wall shall be 18 inches (455 mm). The lateral distance from the centerline of the water closet to a lavatory or bathtub shall be 15 inches (380 mm) minimum. The water closet shall be positioned to allow for future installation of a grab bar on the side with 18 inches (455 mm) clearance. Clearance

around the water closet shall comply with Section 1004.11.3.1.2.1, 1004.11.3.1.2.2, or 1004.11.3.1.2.3.

1004.11.3.1.2.1 Parallel Approach. A clearance 56 inches (1420 mm) minimum measured from the wall behind the water closet, and 48 inches (1220 mm) minimum measured from a point 18 inches (455 mm) from the centerline of the water closet on the side designated for future installation of grab bars shall be provided. Vanities or lavatories on the wall behind the water closet are permitted to overlap the clearance.

1004.11.3.1.2.2 Forward Approach. A clearance 66 inches (1675 mm) minimum measured from the wall behind the water closet, and 48 inches (1220 mm) minimum measured from a point 18 inches (455 mm) from the centerline of the water closet on the side designated for future installation of grab bars shall be provided. Vanities or lavatories on the wall behind the water closet are permitted to overlap the clearance.

1004.11.3.1.2.3 Parallel or Forward Approach. A clearance 56 inches (1420 mm) minimum measured from the wall behind the water closet, and 42 inches (1065 mm) minimum measured from the centerline of the water closet shall be provided.

1004.11.3.1.3 Bathing Facilities. Where a bathtub or shower compartment is provided it shall conform with Section 1004.11.3.1.3.1, 1004.11.3.1.3.2, or 1004.11.3.1.3.3.

1004.11.3.1.3.1 Parallel Approach Bathtubs. A clearance 60 inches (1525 mm) minimum in length and 30 inches (760 mm) minimum in width shall be provided in front of bathtubs with a parallel approach. Lavatories complying with Section 606 shall be permitted in the clearance. A lavatory complying with Section 1004.11.3.1.1 shall be permitted at the control end of the bathtub if a clearance 48 inches (1220 mm) minimum in length and 30 inches (760 mm) minimum in width for a parallel approach is provided in front of the bathtub.

1004.11.3.1.3.2 Forward Approach Bathtubs. A clearance 60 inches (1525 mm) minimum in length and 48 inches (1220 mm) minimum in width shall be

provided in front of bathtubs with a forward approach. A water closet shall be permitted in the clearance at the control end of the bathtub.

1004.11.3.1.3.3 Shower Compartment. If a shower compartment is the only bathing facility, the shower compartment shall have dimensions of 36 inches (915 mm) minimum in width and 36 inches (915 mm) minimum in depth. A clearance of 48 inches (1220 mm) minimum in length, measured perpendicular from the shower head wall, and 30 inches (760 mm) minimum in depth, measured from the face of the shower

compartment, shall be provided. Reinforcing for a shower seat is not required in shower compartments larger than 36 inches (915 mm) in width and 36 inches (915 mm) in depth.

1004.11.3.2 Option B. One of each type of fixture provided shall comply with Section 1004.11.3.2. The accessible fixtures shall be in a single toilet/bathing area, such that travel between fixtures does not require travel through other parts of the unit.

1004.11.3.2.1 Lavatory. Lavatories shall comply with Section 1004.11.3.2.1.

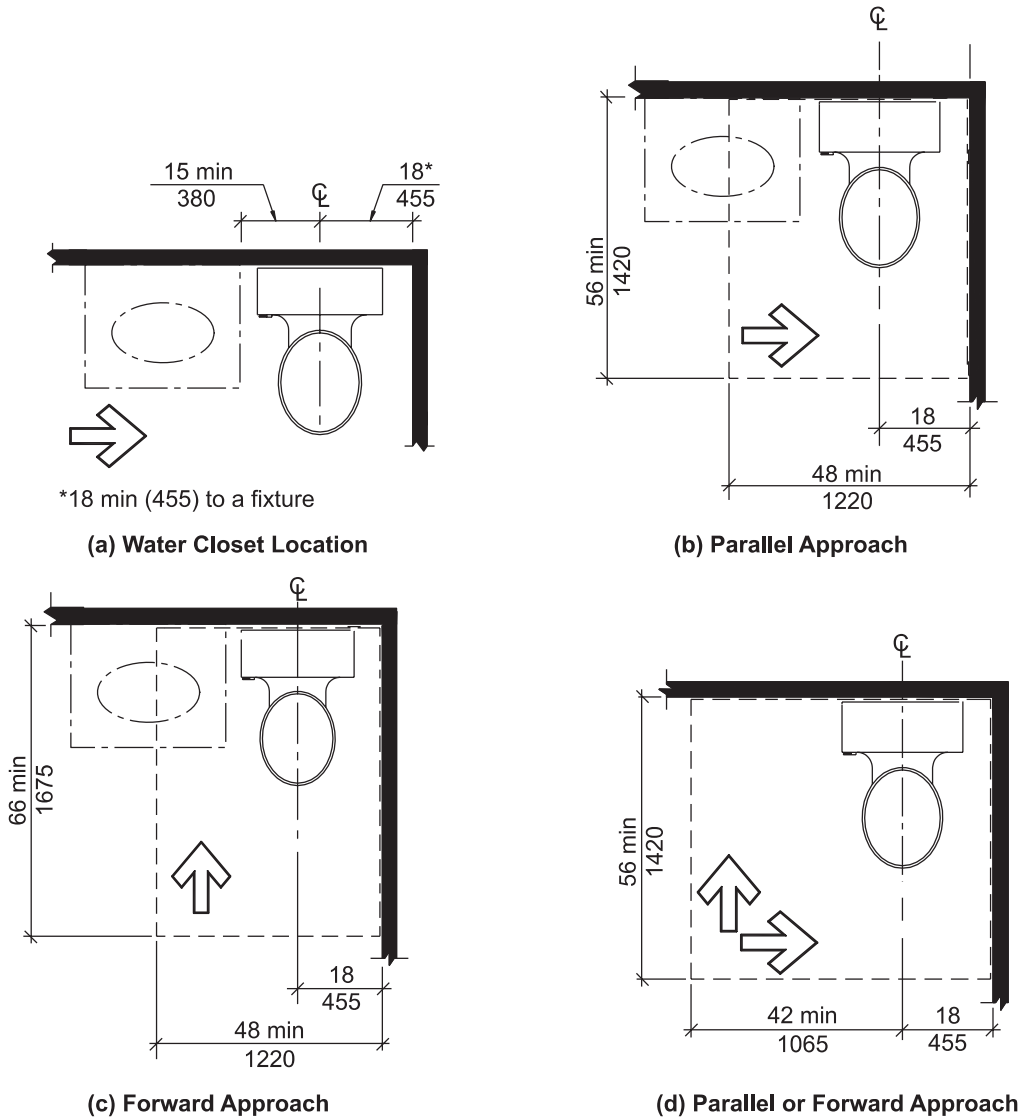

Fig. 1004.11.3.1.2
Water Closets in Type B Units

1004.11.3.2.1.1 Clear Floor Space. A clear floor space complying with Section 305.3, positioned for a parallel approach, shall be provided.

EXCEPTIONS:

1. A lavatory complying with Section 606.
2. Cabinetry shall be permitted under the lavatory, provided such cabinetry can be removed without removal or replacement

of the lavatory, and the floor finish extends under such cabinetry.

1004.11.3.2.1.2 Position. The clear floor space shall be centered on the lavatory.

1004.11.3.2.1.3 Height. The front of the lavatory shall be 34 inches (865 mm) maximum above the floor, measured to the higher of the fixture rim or counter surface.

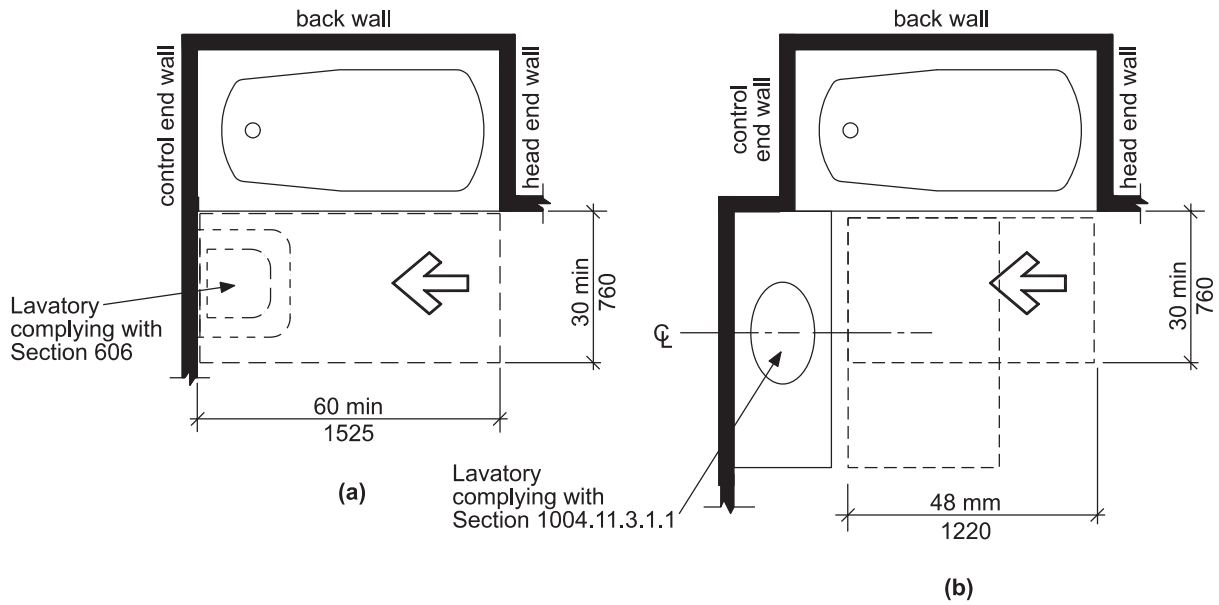

Fig. 1004.11.3.1.3.1 Parallel Approach Bathtub in Type B Units—Option A Bathrooms

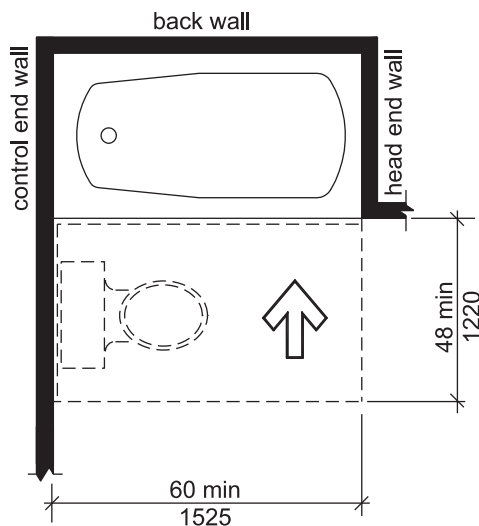

Fig. 1004.11.3.1.3.2 Forward Approach Bathtub in Type B Units—Option A Bathrooms

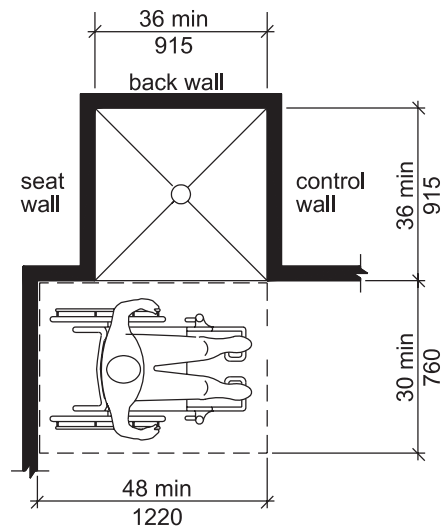

Fig. 1004.11.3.1.3.3 Transfer-Type Shower Compartment in Type B Units

1004.11.3.2.2 Water Closet. The water closet shall comply with Section 1004.11.3.1.2.

1004.11.3.2.3 Bathing Facilities. Where either a bathtub or shower compartment is provided, it shall conform with Section 1004.11.3.2.3.1 or 1004.11.3.2.3.2.

1004.11.3.2.3.1 Bathtub. A clearance 48 inches (1220 mm) minimum in length measured perpendicular from the control end of the bathtub, and 30 inches (760 mm) minimum in width shall be provided in front of bathtubs.

1004.11.3.2.3.2 Shower Compartment. A shower compartment shall comply with Section 1004.11.3.1.3.3.

1004.12 Kitchens. Kitchens shall comply with Section 1004.12.

1004.12.1 Clearance. Clearance complying with Section 1004.12.1 shall be provided.

1004.12.1.1 Minimum Clearance. Clearance between all opposing base cabinets, counter tops, appliances, or walls within kitchen work areas shall be 40 inches (1015 mm) minimum.

1004.12.1.2 U-Shaped Kitchens. In kitchens with counters, appliances, or cabinets on three contiguous sides, clearance between all opposing base cabinets, countertops, appliances, or walls within kitchen work areas shall be 60 inches (1525 mm) minimum.

1004.12.2 Clear Floor Space. Clear floor space at appliances shall comply with Sections 1004.12.2 and 305.3.

1004.12.2.1 Sink. A clear floor space, positioned for a parallel approach to the sink, shall be provided. The clear floor space shall be centered on the sink bowl.

EXCEPTION: Sinks complying with Section 606 shall be permitted to have a clear floor space positioned for a parallel or forward approach.

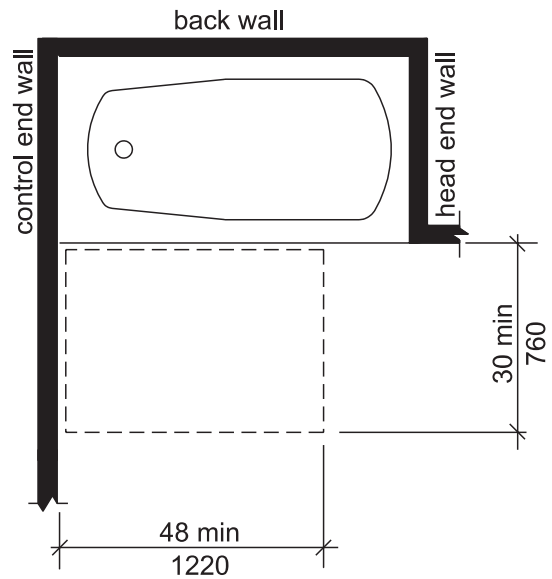
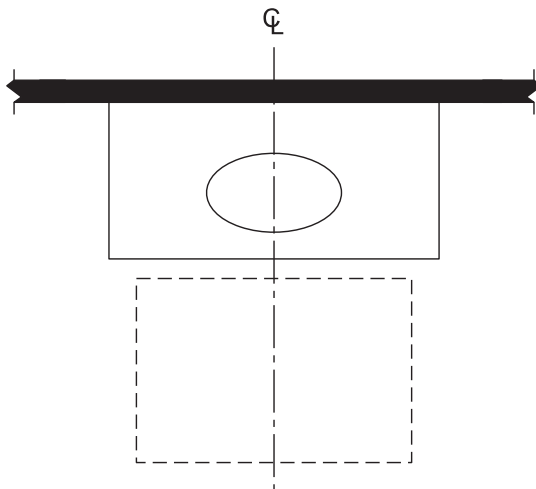
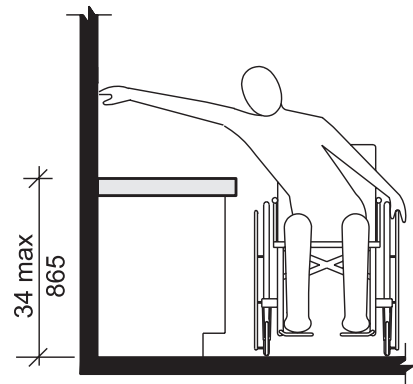

Fig. 1004.11.3.2.3.1 Bathroom Clearance in Type B Units—Option B Bathrooms



(a) Clear Floor Space



(b) Height

Fig. 1004.11.3.2.1 Lavatory in Type B Units—Option B Bathrooms

1004.12.2.2 Dishwasher. A clear floor space, positioned for a parallel or forward approach to the dishwasher, shall be provided. The clear floor space shall be positioned beyond the swing of the dishwasher door.

1004.12.2.3 Cooktop. A clear floor space, positioned for a parallel or forward approach to the cooktop, shall be provided. The centerline of the clear floor space shall align with the centerline of the cooktop. Where the clear floor space is positioned for a forward approach, knee and toe clearance complying with Section 306 shall be provided. Where knee and toe space is provided, the underside of the range or cooktop shall be insulated or otherwise configured to prevent burns, abrasions, or electrical shock.

1004.12.2.4 Oven. A clear floor space, positioned for a parallel or forward approach to the oven, shall be provided.

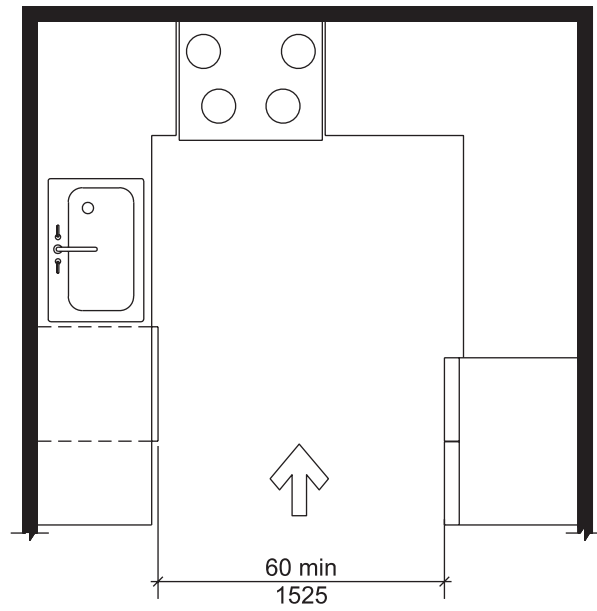
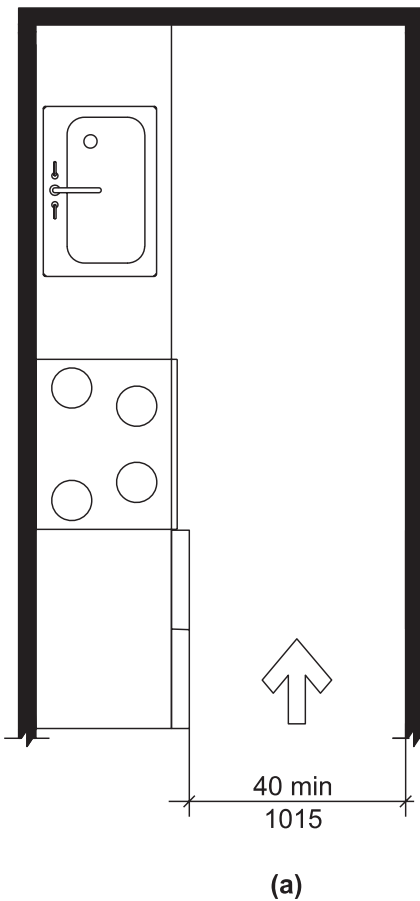
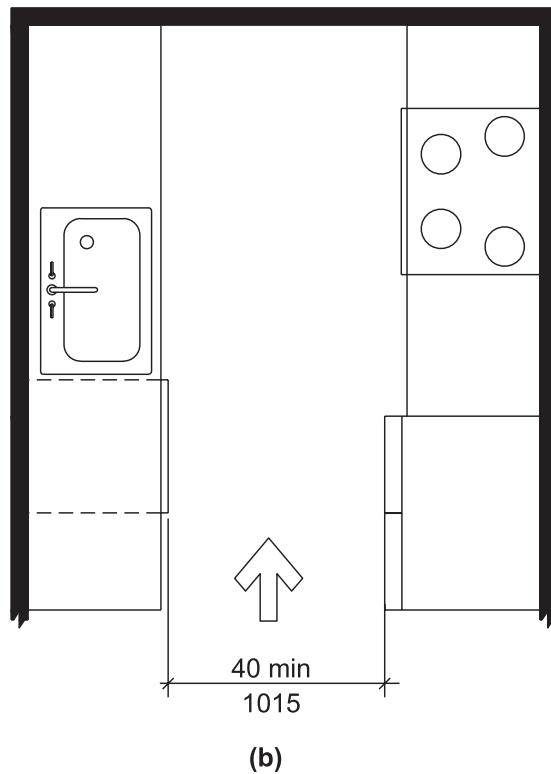

Fig. 1004.12.1.2
U-Shaped Kitchen Clearance in Type B Units



(a)



(b)

Fig. 1004.12.1.1
Minimum Kitchen Clearance in Type B Units

1004.12.2.5 Refrigerator/Freezer. A clear floor space, positioned for a parallel or forward approach to the refrigerator/freezer, shall be provided.

1004.12.2.6 Trash Compactor. A clear floor space, positioned for a parallel or forward approach to the trash compactor, shall be provided.

1005 Units with Accessible Communication Features

1005.1 General. Units required to have accessible communication features shall comply with Section 1005.

1005.2 Unit Smoke Detection. Where provided, unit smoke detection shall include audible notification complying with NFPA 72 listed in Section 105.2.2.

1005.3 Building Fire Alarm System. Where a building fire alarm system is provided, the system wiring shall be extended to a point within the unit in the vicinity of the unit smoke detection system.

1005.4 Visible Notification Appliances. Visible notification appliances, where provided within the unit as part of the unit smoke detection system or the building fire alarm system, shall comply with Section 1005.4.

1005.4.1 Appliance. Visible notification appliances shall comply with Section 702.

1005.4.2 Activation. All visible notification appliances provided within the unit for smoke detection notification shall be activated upon smoke detection. All visible notification appliances provided within the unit for building fire alarm notification shall be activated upon activation of the building fire alarm in the portion of the building containing the unit.

1005.4.3 Interconnection. The same visible notification appliances shall be permitted to provide notification of unit smoke detection and building fire alarm activation.

1005.4.4 Prohibited Use. Visible notification appliances used to indicate unit smoke detection or building fire alarm activation shall not be used for any other purpose within the unit.

1005.5 Unit Primary Entrance. Communication features shall be provided at the unit primary entrance complying with Section 1005.5.

1005.5.1 Notification. A hard-wired electric doorbell shall be provided. A button or switch shall be provided on the public side of the unit pri-

mary entrance. Activation of the button or switch shall initiate an audible tone within the unit.

1005.5.2 Identification. A means for visually identifying a visitor without opening the unit entry door shall be provided. Peepholes, where used, shall provide a minimum 180-degree range of view.

1005.6 Site, Building, or Floor Entrance. Where a system permitting voice communication between a visitor and the occupant of the unit is provided at a location other than the unit entry door, the system shall comply with Section 1005.6.

1005.6.1 Public or Common-Use Interface. The public or common-use system interface shall include the capability of supporting voice and TTY communication with the unit interface.

1005.6.2 Unit Interface. The unit system interface shall include a telephone jack capable of supporting voice and TTY communication with the public or common-use system interface.

1005.7 Closed-Circuit Communication Systems. Where a closed-circuit communication system is provided, the public or common-use system interface shall comply with Section 1005.6.1, and the unit system interface in units required to have accessible communication features shall comply with Section 1005.6.2.